

# INDICE

		classe	pagina
Viti testa esagonale gambo parz. filettato	ISO 4014 - DIN 931 - UNI 5737	Inox A2	2
Viti testa esagonale gambo parz. filettato	ISO 4014 - DIN 931 - UNI 5737	Inox A4	3
Viti testa esagonale gambo int. filettato	ISO 4017 - DIN 933 - UNI 5739	Inox A2	4
Viti testa esagonale gambo int. filettato	ISO 4017 - DIN 933 - UNI 5739	Inox A4	5
Viti testa cilindrica con esagono incassato	ISO 4762 - DIN 912 - UNI 5931	Inox A2	6
Viti testa cilindrica con esagono incassato	ISO 4762 - DIN 912 - UNI 5931	Inox A4	7
Viti testa svasata con esagono incassato	EN10642 -UNI 5933 - DIN 7991	Inox A2	8
Viti testa svasata con esagono incassato	EN10642 - UNI 5933 - DIN 7991	Inox A4	9
Viti testa bombata con esagono incassato	ISO 7380	Inox A2	10
Viti senza testa con esagono incassato	ISO 4026/9 - UNI 5923/9 - DIN 913/6	Inox A2	11
Viti senza testa con esagono incassato	ISO 4027 - UNI 5927 - DIN 914	Inox A2	12
Viti autofilettanti testa cilindrica taglio croce	UNI 6954 -DIN 7981	Inox A2	13
Viti autofilettanti testa cilindrica taglio croce	UNI 6954 -DIN 7981	Inox A4	14
Viti autofilettanti testa svasata taglio croce	UNI 6955 - DIN 7982	Inox A2	15
Viti autofilettanti testa scasata taglio croce	UNI 6955 - DIN 7982	Inox A4	16
Viti testa cilindrica taglio croce	UNI 7687 - DIN7985	Inox A2	17
Viti testa cilindrica taglio croce	UNI 7687 - DIN7985	Inox A4	18
Viti testa svasata taglio croce	UNI 7688 -DIN965	Inox A2	19
Viti testa svasata taglio croce	UNI 7688 -DIN965	Inox A4	20
Viti testa tonda quadro sotto testa	ISO - 8677 DIN 603 - UNI 5732	Inox A2	21
Viti a legno testa esagonale	DIN 571 - UNI 704	Inox A2	22
Viti a legno testa esagonale	DIN 571 - UNI 704	Inox A4	23
Viti per truciolare testa svasata impronta pozy		Inox A2	24
Dadi esagonali	UNI 5587/8/9 - DIN 934/6	Inox A2 - A4	25
Dadi autobloccanti alto - bassi dadi ciechi	UNI 7473-7474-5721 DIN 6924-1587	Inox A2 - A4	26
Rondelle piane	DIN 125	Inox A2 - A4	27
Rondelle grower	DIN 127	Inox A2 - A4	28
Rondelle piane (3 volte il foro)	UNI 6593	Inox A2 - A4	29
Rondelle piane (4 volte il foro)	EXTRA LARGHE	Inox A2 - A4	30

**UNI 5737**

**DIN 931**

**ISO 4014 u** (I DIAMETRI 10, 12, 14, 22 VARIANO UNICAMENTE PER IL VALORE S)

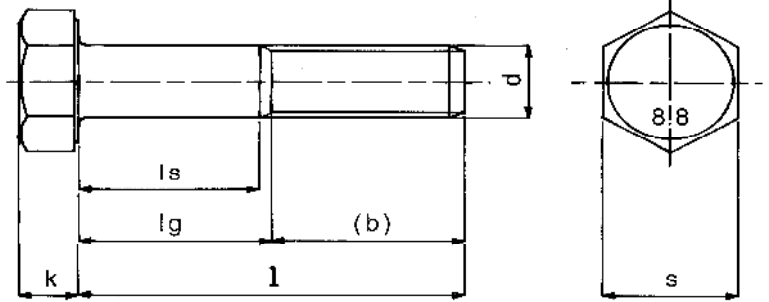

## VITI TESTA ESAGONALE ACCIAIO INOSSIDABILE

d	5	6	8	10	12	14	16	18	20	22	24	27	30
Passo fil.	0,8	1	1,25	1,5	1,75	2	2	2,5	2,5	2,5	3	3	3,5
s	8	10	13	17	19	22	24	27	30	32	36	41	46
s $\blacklozenge$ ISO				16	18	21				34	36		
k	3,5	4	5,3	6,4	7,5	8,8	10	11,5	12,5	14	15	17	19
1 $\leq$ 125	16	18	22	26	30	34	38	42	46	50	54	60	66
b125 $\leq$ 1 > 200	22	24	28	32	36	40	44	48	52	56	60	66	72
> 200				45	49	53	57	61	65	69	73	79	85
ls min.													
lg max.													
	<b>EURO X 100 PEZZI</b>												
	<b>CLASSE A2</b>												
25	8,49	8,02											
30	8,01	7,51	15,84										
35	8,81	8,26	15,84	29,05									
40	9,61	8,48	17,27	29,05	43,58								
45	11,21	8,88	18,85	30,65	43,58	80,71	83,57						
50	12,81	10,32	19,64	32,13	44,44	82,49	90,26						
55	16,01	11,14	22,12	35,60	48,63	85,51	90,46						
60	16,01	12,97	22,98	37,70	51,18	90,15	93,37	181,64	181,64				
65		13,79	25,97	39,59	54,14	96,13	104,00	175,20	175,20				
70		16,49	28,10	45,14	57,82	101,55	106,14	181,84	181,84	480,30	561,96		
75		17,36	30,83	45,21	61,09	108,19	114,93	196,27	196,27	480,30	561,96		
80		22,41	34,22	49,14	67,94	113,40	120,45	204,32	204,32	528,34	427,63	816,52	1084,56
90		24,02	40,10	53,33	75,85	130,76	143,02	224,75	224,75	576,37	464,81	816,52	1104,70
100		28,82	46,24	65,08	82,75	148,08	155,38	246,20	246,20	640,41	527,92	880,56	1184,75
110		33,62	56,04	81,78	92,81	150,17	173,16	261,94	261,94	688,44	531,90	944,60	1264,80
120		38,42	62,44	92,86	107,27	168,05	181,33	294,73	294,73	736,47	595,63	992,63	1344,85
130		51,23	68,84	112,07	140,89	208,13	185,92	352,22	314,14	800,51	619,54	1038,08	1408,89
140		57,64	77,47	128,08	152,10	224,14	225,77	384,24	353,98	880,56	658,74	1088,69	1488,95
150		59,24	84,85	144,09	168,11	248,16	244,16	416,26	384,12	1040,66	721,13	1136,72	1552,99
160		64,04	137,72	176,11	200,13	482,02	278,90	480,30	441,84	1404,92	779,59	1248,79	1713,09
170			149,77	197,97	240,15	636,95	357,56	0,00	526,11	0,00	943,62	1520,97	1793,14
180			175,60	227,24	256,16	688,59	381,57	929,62	583,85	1232,78	998,72	1601,02	1857,18
200			222,08	278,89	320,20	800,51	432,14	981,27	645,73	1344,85	1176,02	1687,11	1969,25

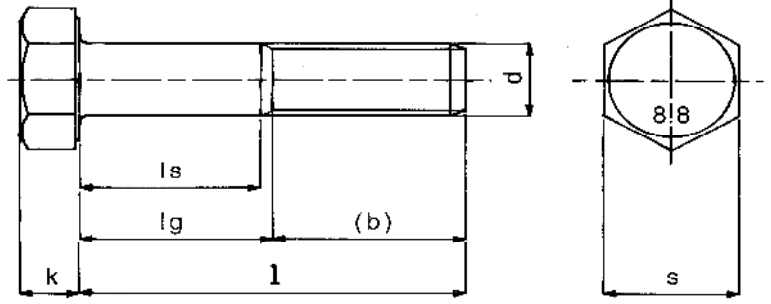

**UNI 5737**

**DIN 931**

**ISO 4014 u** (I DIAMETRI 10, 12, 14, 22 VARIANO UNICAMENTE PER IL VALORE S)

**VITI TESTA ESAGONALE ACCIAIO INOSSIDABILE**

d	5	6	8	10	12	14	16	18	20	22	24	27	30
Passo fil.	0,8	1	1,25	1,5	1,75	2	2	2,5	2,5	2,5	3	3	3,5
s	8	10	13	17	19	22	24	27	30	32	36	41	46
s $\blacklozenge$ ISO				16	18	21				34	36		
k	3,5	4	5,3	6,4	7,5	8,8	10	11,5	12,5	14	15	17	19
1 $\leq$ 125	16	18	22	26	30	34	38	42	46	50	54	60	66
b 125 $\leq$ 1 > 200	22	24	28	32	36	40	44	48	52	56	60	66	72
> 200				45	49	53	57	61	65	69	73	79	85
l <sub>s</sub> min.													
l <sub>g</sub> max.													
	<b>EURO X 100 PEZZI</b>												
	<b>CLASSE A4</b>												
25	11,46	10,83											
30	10,81	8,59	21,38										
35	11,89	11,45	21,38	39,22									
40	12,97	12,69	23,31	39,22	58,83								
45	15,13	13,93	25,45	41,38	58,83	108,96	112,81						
50	17,29	15,04	26,51	43,37	60,00	111,36	121,85						
55	21,61	17,51	29,86	48,06	65,65	115,44	122,12						
60	21,61	18,62	31,40	50,90	69,10	121,70	126,05	245,21	245,21				
65		22,26	35,06	53,45	73,09	129,78	140,40	236,52	236,52				
70		23,43	37,93	56,75	78,06	137,09	143,29	245,48	245,48	648,41	758,62		
75		30,42	41,63	61,03	82,47	146,05	155,16	264,96	264,96		758,62		
80		32,42	46,20	66,34	91,72	153,09	162,61	275,83	275,83	648,41	577,30	1102,33	1464,16
90		38,90	54,13	71,99	102,40	176,53	193,07	303,41	303,41	713,23	627,50	1102,33	1491,37
100		45,39	62,42	87,85	111,71	199,90	209,76	332,37	332,37	778,09	712,71	1188,78	1599,42
110		51,87	75,65	110,40	125,29	202,73	233,76	353,62	353,62	864,55	676,25	1275,24	1707,51
120		69,16	84,30	125,36	144,81	226,87	244,80	397,89	397,89	929,42	804,12	1340,05	1815,55
130		77,81	92,94	151,30	190,20	280,98	251,00	475,50	424,09	994,23	836,40	1404,92	1902,01
140		79,97	104,58	172,91	205,33	302,59	304,79	518,73	477,87	1080,69	889,29	1469,73	2010,10
150		86,45	114,56	144,09	226,95	335,02	329,62	561,91	518,57	1188,73	973,52	1534,60	2096,56
160			185,92	176,11	270,17	650,74	376,52	648,41	596,51	1404,92	1052,44	1685,87	2312,69
170			202,19	197,97	324,21	854,74	17,90		710,28		1273,89	2053,33	2420,74
180			237,05	227,24	345,82	929,62	515,12	1254,99	788,22	1664,28	1348,26	2161,37	2507,19
200			299,80	278,89	432,27	1080,69	583,39	1324,71	871,68	1815,55	1587,64	2277,57	2658,51

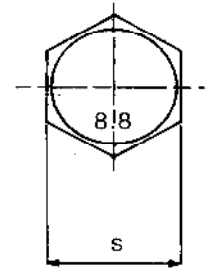
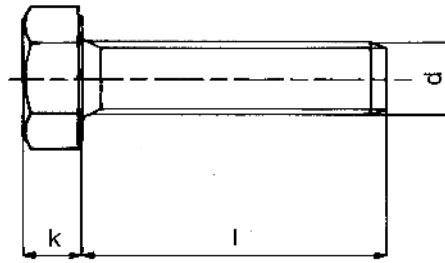

**UNI 5739**

**DIN 933**

**ISO 4017 u** (I DIAMERTI 10, 12, 14, 22 VARIANO UNICAMENTE PER IL VALORE S)

**VITI TESTA ESAGONALE ACCIAIO INOSSIDABILE**

d	3	4	5	6	8	10	12	14	16	18	20	22	24	27	30	
Passo fil.		0,7	0,8	1	1,25	1,5	1,75	2	2	2,5	2,5	2,5	3	3	3,5	
s		7	8	10	13	17	19	22	14	27	30	32	36	41	46	
s ◆ ISO						16	18	21				34				
k		2,8	3,5	4	5,3	6,4	7,5	8,8	10	11,5	12,5	14	15	17	19	
6	4,13	4,13														<b>EURO X 100 PEZZI</b> <b>CLASSE A2</b>
8	4,13	4,13	4,82	5,85												
10	4,13	4,13	4,01	5,01	11,36	24,96										
12	4,13	4,13	3,89	4,81	10,02	24,10										
14	4,48	4,58	4,47	4,99	11,86	22,38										
16	4,48	4,65	4,22	4,73	9,20	18,41	36,15									
18	4,82	5,33	4,86	5,76	10,56	19,84										
20	4,82	5,00	4,70	5,22	9,97	18,71	31,14	65,34	79,19							
25	5,68	5,68	5,18	6,00	11,07	19,63	29,54	64,93	64,93		189,42					
30	6,20	6,35	5,94	6,95	12,48	20,86	30,96	61,20	66,31	122,86	150,83					
35		7,34	6,46	7,86	13,75	23,47	33,54	64,22	64,96	129,77	127,31					
40		8,82	7,36	8,69	15,19	24,24	35,84	68,77	70,00	129,77	131,71	336,21	294,45			
45		11,19	9,61	9,51	16,69	27,71	39,32	74,04	74,29	133,65	136,31	336,21	303,76			
50		12,05	11,21	10,30	18,66	29,50	41,01	78,64	77,46	139,68	140,61	352,22	309,74	5272,51		
55			13,61	14,57	20,55	32,98	47,93	83,39	84,72	145,77	153,64	400,25	345,63			
60			13,61	15,44	21,27	35,79	50,77	89,07	89,63	154,05	157,22	400,25	343,64	680,43	880,56	
65				20,01	24,12	40,90	55,73	96,02	97,15	161,77	171,44	432,27	366,90			
70				22,09	29,15	44,48	59,97	100,06	104,97	167,86	178,95	432,27	381,52	736,47	944,60	
75				24,79	32,02	50,10	69,72	111,04	113,62	0,00	196,25					
80				25,62	33,62	52,31	74,34	116,57	119,23	193,42	207,07	464,29	428,72	784,50	1008,64	
90				30,42	44,83	67,24	86,45	163,55	144,09	292,66	232,15	528,34	512,33	848,54	1072,68	
100				36,82	52,83	75,25	96,06	172,14	160,10	320,20	248,16	592,38	560,36	896,57	1136,72	

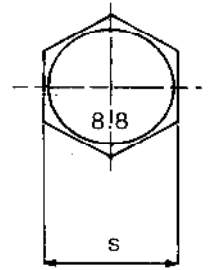
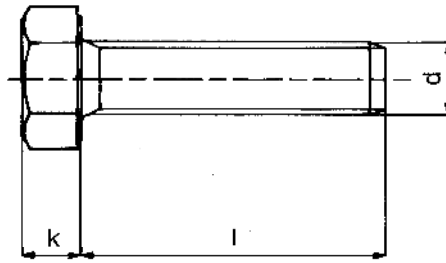

**UNI 5739**

**DIN 933**

**ISO 4017 u** (I DIAMERTI 10, 12, 14, 22 VARIANO UNICAMENTE PER IL VALORE S)

**VITI TESTA ESAGONALE ACCIAIO INOSSIDABILE**

d	3	4	5	6	8	10	12	14	16	18	20	22	24	27	30	
Passo fil.		0,7	0,8	1	1,25	1,5	1,75	2	2	2,5	2,5	2,5	3	3	3,5	
s		7	8	10	13	17	19	22	14	27	30	32	36	41	46	
s ◆ ISO						16	18	21				34				
k		2,8	3,5	4	5,3	6,4	7,5	8,8	10	11,5	12,5	14	15	17	19	
6	5,58	5,58														<b>EURO X 100 PEZZI</b> <b>CLASSE A4</b>
8	5,58	5,58	6,51	7,90												
10	5,58	5,58	5,41	6,77	15,34	33,70										
12	5,58	5,56	5,25	6,49	13,53	32,54										
14	6,04	6,18	6,03	6,73	16,01	30,21										
16	6,04	6,28	5,70	6,39	12,42	24,86	48,81									
18	6,51	7,20	6,56	7,77	14,26	26,79										
20	6,51	6,76	6,35	7,05	13,46	25,26	42,03	88,21	106,91							
25	7,67	7,67	6,99	8,10	14,94	26,50	40,24	87,66	87,66		255,65					
30	8,37	8,60	8,02	9,38	16,85	28,16	41,80	82,62	89,52	165,86	203,62					
35		9,91	8,72	10,61	18,56	31,68	45,28	86,70	87,70	175,19	171,87					
40		11,90	9,94	11,73	20,50	32,72	48,39	92,84	94,50	175,19	177,81	453,89	379,51			
45		15,11	12,97	12,83	22,53	37,41	53,08	99,95	100,29	180,43	184,02	453,89	410,07			
50		16,27	15,13	13,90	25,19	39,82	55,36	106,16	104,57	188,57	189,82	475,50	418,15	842,94		
55			18,37	19,67	27,74	44,52	64,70	112,58	114,37	196,79	207,41	540,34	466,60			
60			18,37	20,85	28,71	48,32	68,54	120,24	121,00	207,97	212,25	540,34	463,92	918,58	1188,75	
65				27,02	32,56	55,21	75,24	129,63	131,15	218,39	231,44	583,57	495,31			
70				14,33	39,35	60,04	80,96	135,08	141,71	226,61	241,58	583,57	515,06	994,23	1275,21	
75				33,47	43,23	67,61	94,12	149,90	153,39		264,94					
80				34,58	45,39	70,62	100,36	157,37	160,96	261,12	279,54	626,80	578,76	1059,07	1361,66	
90				41,07	60,52	90,78	116,71	220,79	194,52	395,09	313,40	713,25	691,64	1145,53	1448,12	
100				49,71	71,33	101,59	129,68	232,41	216,14	423,27	335,01	799,71	756,48	1210,37	1534,57	

**UNI 5931**  
**DIN 912**  
**ISO 4762**

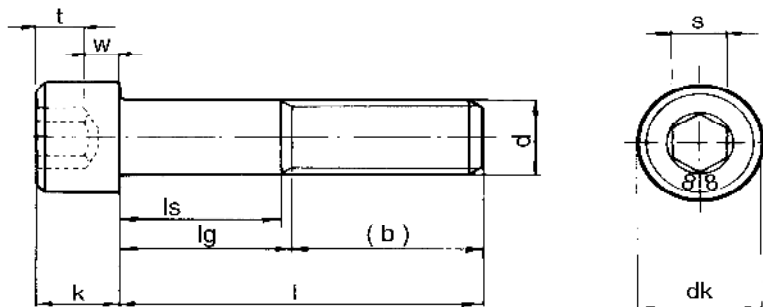

## VITI TESTA CILINDRICA CON ESAGONO INCASSATO ACCIAIO INOSSIDABILE

d	3	4	5	6	8	10	12	14	16	18	20	22	24
Passo fil.	0,5	0,7	0,8	1	1,25	1,5	1,75	2	2	2,5	2,5	2,5	3
dk	5,5	7	8,5	10	12	16	18	21	24	27	30	33	36
k	3	4	5	6	8	10	12	14	16	18	20	22	24
s	2,5	3	4	5	6	8	10	12	14	14	17	17	29
t min.	1,3	2	2,5	3	4	5	6	7	8	9	10	11	12
w min	1,15	1,4	1,9	2,3	3	4	4,8	5,8	6,8	7,8	8,6	9,4	10,4
(b)	18	20	22	24	28	32	36	40	44	48	52	56	60
ls min.	ls min = lg max. - 5 volte il passo												
lg max.	lg max. = 1 - (b)												
6	5,12	5,12	8,01										
8	4,80	4,38	5,60	8,01									
10	4,48	4,03	4,33	6,80	14,09								
12	4,16	3,79	4,28	5,32	12,16								
14	4,80	4,28	5,02	7,53	15,34								
16	4,48	4,17	4,33	5,60	11,35	37,52							
18	5,44	4,58	5,47	7,76	13,65	25,65							
20	5,12	4,26	4,74	6,49	12,97	20,78	32,13		112,07				
25	5,76	5,05	5,88	7,03	13,23	21,90	31,12	100,86	104,91				
30	6,72	5,67	7,03	7,87	14,69	23,73	33,78	100,86	100,06	256,16			
35	8,01	6,53	8,13	9,48	16,31	25,95	39,83	105,67	100,06	256,16			
40	8,81	7,16	8,95	10,36	18,71	27,07	40,23	112,07	103,74	256,16			800,51
45		10,33	10,74	12,06	22,21	30,74	42,35	120,08	113,79	271,14			800,51
50		11,88	13,11	13,78	23,83	34,08	45,84	126,48	116,30	280,18			800,51
55			16,11	15,93	25,50	39,00	51,50	136,09	128,02	304,19			
60			17,51	17,04	28,01	42,27	55,83	144,09	135,41	320,20			896,57
65			25,31	22,72	32,02	47,98	60,76	160,10	148,20	352,22			
70			27,22	24,28	33,83	51,45	68,84	168,11	159,04	368,23			1088,69
80			32,02	30,99	44,66	61,05	82,43	192,12	187,20	448,28			1200,76
90				33,62	53,42	74,89	95,52	224,14	219,37	480,30			1344,85
100				44,83	59,08	86,70	107,78	256,16	245,70	512,33			1472,94
110				56,04	88,06	128,08	152,10	288,18	288,18	608,39			1681,07
120				64,04	100,86	144,09	168,11	321,20	312,20	672,43			1761,12
130				72,05	112,07	160,10	200,13	344,22	344,22	768,49			2001,27
140				88,06	123,28	176,11	224,14	376,24	376,24	880,56			2161,37
150				104,07	134,49	192,12	248,16	400,25	400,25	960,61			231,47
160													
180													
200													
220													
240													
260													
280													
300													

**EURO X 100 PEZZI**  
**CLASSE A2**

**UNI 5931**  
**DIN 912**  
**ISO 4762**

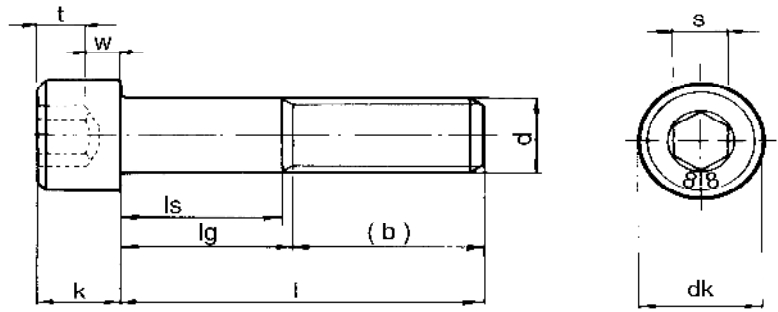

## VITI TESTA CILINDRICA CON ESAGONO INCASSATO ACCIAIO INOSSIDABILE

d	3	4	5	6	8	10	12	14	16	18	20	22	24
Passo fil.	0,5	0,7	0,8	1	1,25	1,5	1,75	2	2	2,5	2,5	2,5	3
dk	5,5	7	8,5	10	12	16	18	21	24	27	30	33	36
k	3	4	5	6	8	10	12	14	16	18	20	22	24
s	2,5	3	4	5	6	8	10	12	14	14	17	17	19
t min.	1,3	2	2,5	3	4	5	6	7	8	9	10	11	12
w min	1,15	1,4	1,9	2,3	3	4	4,8	5,8	6,8	7,8	8,6	9,4	10,4
(b)	18	20	22	24	28	32	36	40	44	48	52	56	60
ls min.	ls min = lg max. - 5 volte il passo												
lg max.	lg max. = 1 - (b)												
6	6,92	6,92	10,81										
8	6,48	5,91	7,56	10,81									
10	6,05	5,44	5,85	9,18	19,02								
12	5,62	5,12	5,78	7,18	16,42								
14	6,48	5,78	6,78	10,17	20,71								
16	6,05	5,63	5,85	7,56	15,32	37,15							
18	7,35	6,18	7,38	10,48	18,43	34,63							
20	6,92	5,75	8,14	8,76	17,51	28,05	43,38		151,30				
25	7,78	6,82	7,94	9,49	17,86	29,57	42,01	136,17	141,62				
30	9,08	7,65	9,49	10,62	19,83	32,04	45,60	136,17	135,09	345,82			
35	10,81	8,82	10,98	12,80	220,02	35,03	49,72	142,65	135,09	345,82			
40	11,89	9,67	12,08	13,99	25,26	36,54	54,31	151,30	140,05	345,82		1080,69	
45		13,94	14,50	16,28	29,98	41,50	57,17	162,10	153,62	366,04		1080,69	
50		16,04	17,70	18,60	32,17	46,01	61,88	170,75	157,01	378,24		1080,69	
55			21,75	21,51	34,43	52,65	69,53	173,72	172,83	410,66			
60			23,64	23,00	37,81	57,06	75,37	194,52	182,80	432,27		11210,37	
65			34,16	30,68	43,32	64,77	82,03	216,14	200,07	475,50			
70			36,74	32,78	45,67	69,46	92,93	226,94	214,70	497,12		1469,73	
80			43,23	41,83	60,29	82,42	111,28	259,36	252,72	605,18		1621,03	
90			17,85	45,39	72,12	101,10	128,05	302,59	296,15	648,41		1815,55	
100			21,85	60,52	79,76	117,05	145,50	345,82	331,70	691,64		1988,46	
110			26,50	75,65	118,88	172,91	205,33	389,05	389,05	821,32		2269,44	
120			31,80	86,45	136,17	194,52	226,94	421,47	421,47	907,78		2377,51	
130			173,45	97,26	151,30	216,14	270,17	464,70	464,70	1037,46		2701,72	
140				118,88	166,43	237,75	302,59	507,92	507,92	1188,75		2917,85	
150				140,49	181,46	259,36	335,01	540,34	540,34	1296,82		3133,99	
160													
180													
200													
220													
240													
260													
280													
300													

**EURO X 100 PEZZI**  
**CLASSE A4**

**UNI 5933  
DIN 7991 - A**

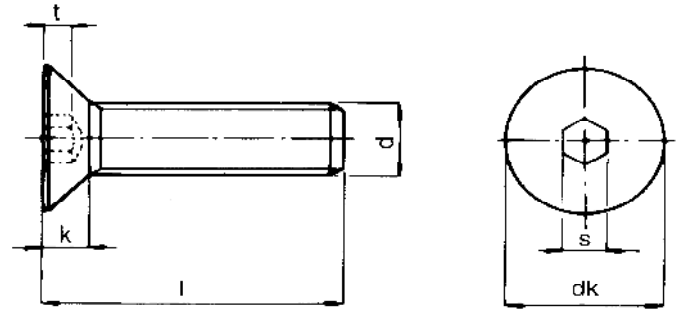

**VITI TESTA SVASATA PIANA CON ESAGONO INCASSATO ACCIAIO INOSSIDABILE**

d	3	4	5	6	8	10	12	14	16	18	20
Passo fil.	0,5	0,7	0,8	1	1,25	1,5	1,75	2	2	2,5	2,5
dk	6	8	10	12	16	20	24	27	30	33	36
k	1,7	2,3	2,8	3,3	4,4	5,5	6,5	7	7,5	8	8,5
s	2	2,5	3	4	5	6	8	10	10	12	12
t	1,2	1,8	2,3	2,5	3,5	4,4	4,6	4,8	5,3	5,5	5,9
6	4,80	4,80	8,01						<b>EURO X 100 PEZZI CLASSE A2</b>		
8	4,48	4,48	5,76	6,40							
10	4,00	4,00	4,48	6,03	12,91						
12	3,84	3,84	4,48	5,28	10,41						
14	4,16	4,16	5,28	6,40	13,61						
16	3,84	3,84	4,48	5,44	10,41	27,54					
18	5,12	5,12	5,60	6,88	13,61	30,99					
20	4,48	4,48	4,96	6,08	11,53	20,81	43,23				
25	5,44	5,44	5,76	6,88	12,17	22,41	46,43		192,12		
30	6,40	6,40	6,72	8,01	13,77	24,82	51,23		160,10		
35	7,20	7,20	8,17	9,13	16,01	27,70	54,43		168,11		
40	7,49	8,49	9,29	10,57	18,25	29,62	59,24	176,11			352,22
45		10,41	12,01	12,49	20,49	33,62	64,04	184,12			368,23
50		11,53	13,61	13,61	23,21	36,82	67,24	200,13			384,24
55			19,11	15,69	25,62	41,63	75,75				
60			20,01	17,90	28,18	44,03	88,06	216,14			416,26
70			28,82	25,31	38,42	57,64	112,07	256,16			480,30
80			43,23	33,62	49,63	80,05	132,88	272,17			560,36
90				40,03	59,24	96,06	140,89	296,19			608,39
100				48,03	64,04	112,07	147,29	320,20			656,42

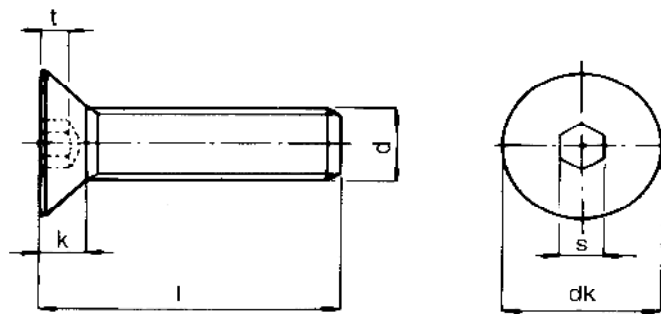

**UNI 5933  
DIN 7991- A**

**VITI TESTA SVASATA PIANA ESAGONO INCASSATO ACCIAIO INOSSIDABILE**

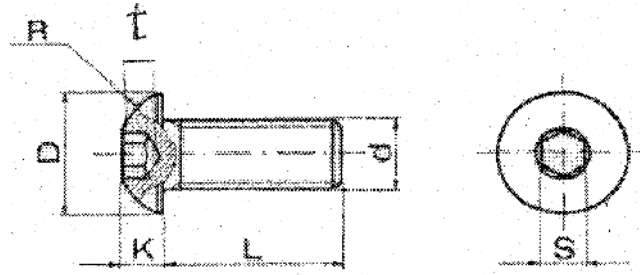
d	3	4	5	6	8	10	12	14	16	18	20
Passo fil.	0,5	0,7	0,8	1	1,25	1,5	1,75	2	2	2,5	2,5
dk	6	8	10	12	16	20	24	27	30	33	36
k	1,7	2,3	2,8	3,3	4,4	5,5	6,5	7	7,5	8	8,5
s	2	2,5	3	4	5	6	8	10	10	12	12
t	1,2	1,8	2,3	2,5	3,5	4,4	4,6	4,8	5,3	5,5	5,9
6	6,48	6,48	10,81						<b>EURO X 100 PEZZI CLASSE A4</b>		
8	6,05	6,05	7,78	8,65							
10	5,40	5,40	6,05	8,13	17,43						
12	5,19	5,19	6,05	7,13	14,05						
14	5,62	5,62	7,13	8,65	18,37						
16	5,19	5,19	6,05	7,35	14,05	37,18					
18	6,92	6,92	7,56	9,29	18,37	41,83					
20	6,05	6,05	6,70	8,21	15,56	27,10	58,36				
25	7,35	7,35	7,78	9,29	16,43	30,26	62,68		259,36		
30	8,65	8,65	9,08	10,81	18,59	33,50	69,19		216,14		
35	9,73	9,73	11,02	12,32	21,61	37,39	73,49		226,94		
40	11,46	11,46	12,54	14,27	24,64	39,99	79,97		237,75		475,50
45		14,05	16,21	16,86	27,67	45,39	86,45		248,56		497,12
50		15,56	18,37	18,37	31,34	49,71	90,78		270,17		518,73
55			25,80	21,18	34,58	56,20	102,26				
60			27,02	24,17	38,04	59,44	118,88		291,79		561,96
70			38,90	34,17	51,87	77,81	151,30		342,82		648,41
80			58,36	45,39	67,00	108,07	179,39		367,43		756,48
90				54,03	79,97	129,68	190,20		399,85		821,32
100				64,84	86,45	151,30	198,85		432,27		883,16



**ISO 7380**

**VITI TESTA BOMBATA CON ESAGONO INCASSATO ACCIAIO INOSSIDABILE**

d	3	4	5	6	8	10	12
Passo fil.	0,5	0,7	0,8	1	1,25	1,5	1,75
D	5,7	7,6	9,5	10,5	14	17,5	21
k	1,65	2,2	2,75	3,3	4,4	5,5	6,5
s	2	2,5	3	4	5	6	8
t	1,4	3,4	6,8	11	28	55	95
6	3,55	3,87					
8	3,07	3,07	4,36	5,97			
10	3,39	3,39	4,68	5,65	13,72		
12	3,71	3,71	4,84	5,97	13,72	25,82	
16	4,03	4,03	5,16	6,78	13,40	27,44	
20	4,52	4,52	5,81	7,42	14,04	29,05	
25	4,84	4,84	6,78	8,07	14,85	32,28	54,87
30	7,26	5,81	7,26	9,04	17,75	35,51	59,72
35		8,07	8,07	10,49	20,17	40,35	66,17
40		9,68	8,88	11,62	23,40	42,77	71,01
45				13,56	26,63	45,19	75,85
50			19,37	15,49	29,86	51,65	80,70
55							
60				17,75	37,12	64,56	93,61
70							

**EURO X 100 PEZZI  
CLASSE A2**

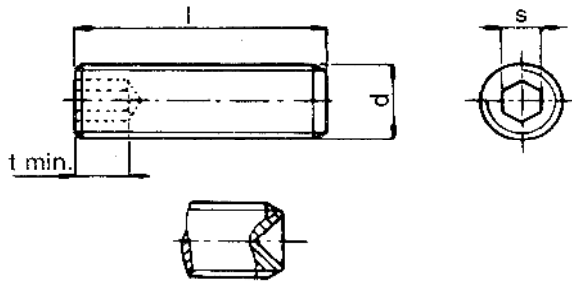

**UNI 5923/9**  
**DIN 913/16**  
**ISO 4026/4029**

**VITI SENZA TESTA CON ESAGONO INCASSATO PUNTA PIATTA / COPPA**

d	3	4	5	6	8	10	12	14	16	20		
Passo fil.	0,5	0,7	0,8	1	1,25	1,5	1,75	2	2	2,5		
s	1,5	2	2,5	3	4	5	6	6	8	10		
t min:	1,2	1,5	2	2	3	4	4,5	5,6	6,4	8		
3	7,23	<b>EURO X 100 PEZZI</b> <b>CLASSE A2</b>										
4	5,82										5,87	
5	5,29										5,11	5,99
6	5,40										5,29	4,30
8	5,64	5,64	5,58	7,23	11,28							
10	6,11	5,87	5,87	7,64	11,28	20,80						
12	6,81	6,70	6,34	8,05	13,04	19,74	31,72					
14	12,16	10,57	6,81	9,46	13,51	23,97	37,36					
16	12,16	10,57	8,11	9,46	13,51	23,97	37,36	123,64	131,45			
20	16,39	14,28	8,11	11,28	16,92	26,79	43,00	124,94	149,67	648,57		
25		20,98	9,87	16,92	21,15	31,55	50,76	143,16	169,19	587,61		
30		29,05	15,51	21,15	23,79	35,95	58,51	160,08	182,62	727,74		
35		40,35	19,03	23,97	26,79	44,51	67,68	178,30	218,65	766,78		
40		43,58	21,85	25,73	29,26	46,53	74,73	197,82	239,47	805,83		
45			23,97	38,73	37,36	58,51	81,78	227,76	277,21	871,99		
50			58,10	40,35	38,77	59,92	97,99	244,68	299,34	885,00		
60			61,33	50,03	64,56	100,60	145,25	282,42	354,00	950,07		
70						145,25	169,46	324,07	415,17	1020,57		

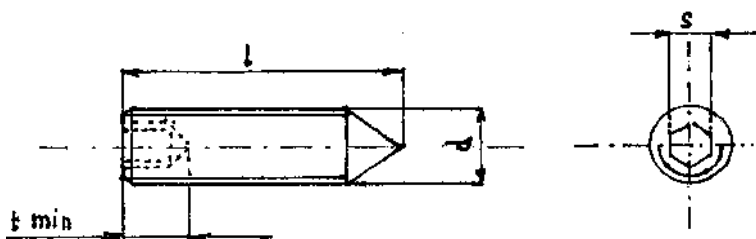

**UNI 5927**  
**DIN 914**  
**ISO 4027**

## VITI SENZA TESTA CON ESAGONO INCASSATO PUNTA CONICA

d	3	4	5	6	8	10	12	14	16	20
Passo fil.	0,5	0,7	0,8	1	1,25	1,5	1,75	2	2	2,5
s	1,5	2	2,5	3	4	5	6	6	8	10
t min:	1,2	1,5	2	2	3	4	4,5	5,6	6,4	8
3	7,23	<b>EURO X 100 PEZZI</b> <b>CLASSE A2</b>								
4	5,82									
5	5,29	5,11	5,99							
6	5,40	5,29	4,30	6,46						
8	5,64	5,64	5,58	7,23	11,28					
10	6,11	5,87	5,87	7,64	11,28	20,80				
12	6,81	6,70	6,34	8,05	13,04	19,74	31,72			
14	12,16	10,57	6,81	9,46	13,51	23,97	37,36			
16	12,16	10,57	8,11	9,46	13,51	23,97	37,36	123,64	131,45	
20	16,39	14,28	8,11	11,28	16,92	26,79	43,00	124,94	149,67	648,57
25		20,98	9,87	16,92	21,15	31,55	50,76	143,16	169,19	587,61
30		29,05	15,51	21,15	23,79	35,95	58,51	160,08	182,62	727,74
35		40,35	19,03	23,97	26,79	44,51	67,68	178,30	218,65	766,78
40		43,58	21,85	25,73	29,26	46,53	74,73	197,82	239,47	805,83
45			23,97	38,73	37,36	58,51	81,78	227,76	277,21	871,99
50			58,10	40,35	38,77	59,92	97,99	244,68	299,34	885,00
60			61,33	50,03	64,56	100,60	145,25	282,42	354,00	950,07
70						145,25	169,46	324,07	415,17	1020,57

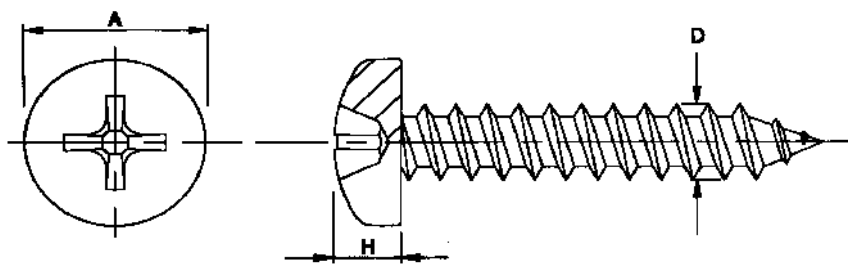
**UNI 6954  
DIN 7981**

**VITI AUTOFILETTANTI TESTA CILINDRICA T. CROCE ACCIAIO INOSSIDABILE**

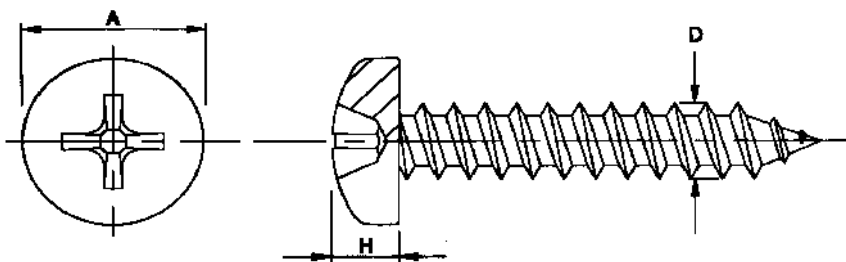
d	2,2	2,9	3,5	3,9	4,2	4,8	5,5	6,3
a min	3,95	5,30	6,54	7,14	7,84	9,14	10,37	12,07
a max	4,20	5,60	6,85	7,50	8,17	9,47	10,80	12,49
h min	1,55	1,95	2,35	2,55	2,75	3,25	3,65	4,25
h max	1,80	2,10	2,50	2,75	2,95	3,45	3,90	4,50
Impronta PH	1	1	2	2	2	2	3	3
6,5	1,96	1,25	1,50	1,88	2,24	<b>EURO X 100 PEZZI CLASSE A2</b>		
9,5	1,96	1,25	1,50	1,88	2,06			
13	2,14	1,37	1,64	2,04	2,24	3,37	5,29	6,39
16	2,14	1,49	1,71	2,19	2,51	3,74	5,64	6,88
19		1,68	1,92	2,63	2,77	4,04	6,03	7,95
22		2,04	2,21	2,90	2,99	4,45	6,90	8,64
25		2,23	2,78	3,06	3,18	4,64	4,48	9,58
32		4,54	3,13	4,19	4,19	5,24	8,78	11,14
38			3,67	4,47	5,05	6,36	9,60	12,33
45			8,26	7,75	6,54	8,64	12,93	15,61
50			9,30	8,26	7,89	9,57	14,22	17,57
60					15,49	13,99	15,95	19,37
70					22,72	18,92	21,63	25,68
80						24,68	28,88	34,69

**UNI 6954  
DIN 7981**

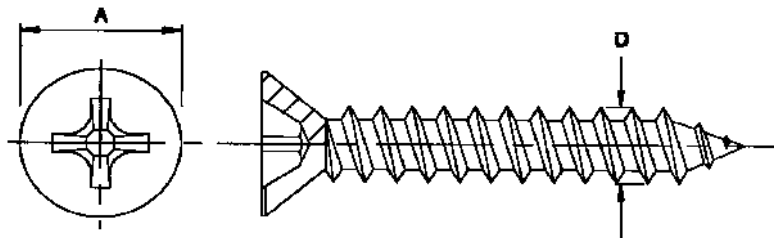
**VITI AUTOFILETTANTI TESTA CILINDRICA T. CROCE ACCIAIO INOSSIDABILE**

d	2,2	2,9	3,5	3,9	4,2	4,8	5,5	6,3
a min	3,95	5,30	6,54	7,14	7,84	9,14	10,37	12,07
a max	4,20	5,60	6,85	7,50	8,17	9,47	10,80	12,49
h min	1,55	1,95	2,35	2,55	2,75	3,25	3,65	4,25
h max	1,80	2,10	2,50	2,75	2,95	3,45	3,90	4,50
Impronta PH	1	1	2	2	2	2	3	3
6,5	3,55	2,26	2,69	3,39			<b>EURO X 100 PEZZI CLASSE A2</b>	
9,5	3,55	2,26	2,69	3,39	3,72	6,06		
13	3,85	2,49	2,95	3,67	4,04	6,06	9,54	11,50
16	3,85	2,68	3,08	3,95	4,53	6,73	10,16	12,39
19		3,06	3,46	4,75	4,98	7,27	10,86	14,30
22		3,67	3,97	5,22	5,39	8,03	12,41	15,58
25		4,04	5,00	5,50	5,74	8,35	13,49	17,25
32		7,73	5,64	7,57	7,54	9,42	15,80	20,05
38			6,62	8,04	9,11	11,44	17,30	22,22
45			14,05	13,17	11,80	15,57	23,27	28,12
50			15,80	14,05	14,23	17,23	25,61	31,65
60					26,34	25,18	28,73	34,90
70					38,63	34,06	38,93	46,25
80					22,72	44,43	52,00	62,47

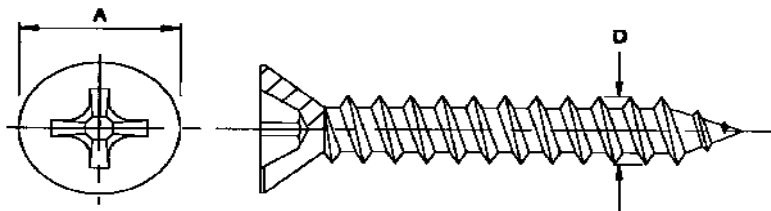

**UNI 6955  
DIN 7982**
**VITI AUTOFILETTANTI TESTA SVASATA T. CROCE ACCIAIO INOSSIDABILE**

d	2,2	2,9	3,5	3,9	4,2	4,8	5,5	6,3
a min	4,05	5,20	6,44	7,14	7,74	9,14	10,37	11,97
a max	4,30	5,50	6,80	7,50	8,10	9,50	10,80	12,40
Impronta PH	1	1	2	2	2	2	3	3
6,5	1,96	1,25	1,50	1,88	2,24	<b>EURO X 100 PEZZI CLASSE A2</b>		
9,5	1,96	1,25	1,50	1,88	2,06			
13	2,14	1,37	1,64	2,04	2,24	3,37	5,29	6,39
16	2,14	1,49	1,71	2,19	2,51	3,74	5,64	6,88
19		1,68	1,92	2,63	2,77	4,04	6,03	7,95
22		2,04	2,21	2,90	2,99	4,45	6,90	8,64
25		2,23	2,78	3,06	3,18	4,64	4,48	9,58
32		4,54	3,13	4,19	4,19	5,24	8,78	11,14
38			3,67	4,47	5,05	6,36	9,60	12,33
45			8,26	7,75	6,54	8,64	12,93	15,61
50			9,30	8,26	7,89	9,57	14,22	17,57
60					15,49	13,99	15,95	19,37
70					22,72	18,92	21,63	25,68
80						24,68	28,88	34,69

**UNI 6954  
DIN 7981**
**VITI AUTOFILETTANTI TESTA SVASATA T. CROCE ACCIAIO INOSSIDABILE**

d	2,2	2,9	3,5	3,9	4,2	4,8	5,5	6,3
a min	4,05	5,20	6,44	7,14	7,74	9,14	10,37	11,97
a max	4,30	5,50	6,80	7,50	8,10	9,50	10,80	12,40
h min								
h max								
Impronta PH	1	1	2	2	2	2	3	3
6,5	3,55	2,26	2,69	3,39			<b>EURO X 100 PEZZI CLASSE A2</b>	
9,5	3,55	2,26	2,69	3,39	3,72	6,06		
13	3,85	2,49	2,95	3,67	4,04	6,06	9,54	11,50
16	3,85	2,68	3,08	3,95	4,53	6,73	10,16	12,39
19		3,06	3,46	4,75	4,98	7,27	10,86	14,30
22		3,67	3,97	5,22	5,39	8,03	12,41	15,58
25		4,04	5,00	5,50	5,74	8,35	13,49	17,25
32		7,73	5,64	7,57	7,54	9,42	15,80	20,05
38			6,62	8,04	9,11	11,44	17,30	22,22
45			14,05	13,17	11,80	15,57	23,27	28,12
50			15,80	14,05	14,23	17,23	25,61	31,65
60					26,34	25,18	28,73	34,90
70					38,63	34,06	38,93	46,25
80					22,72	44,43	52,00	62,47

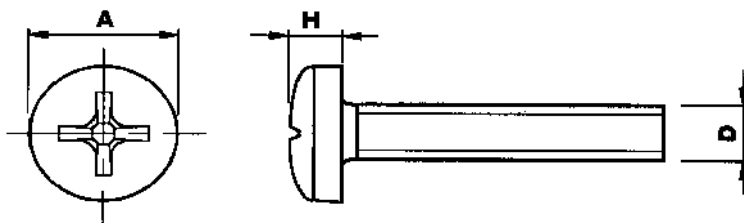



**UNI 7687**  
**DIN 7985**
**VITI METALLO TESTA CILINDRICA TAGLIO CROCE ACCIAIO INOSSIDABILE**

d	3	4	5	6	8
Passo fil.	0,5	0,7	0,8	1	1,25
a	6	8	10	12	16
h max	2,52	3,25	3,95	4,75	6,15
Impronta PH	1	2	2	3	4
4	2,69				
5	1,48	2,58			
6	1,40	2,40	5,68		
8	1,36	2,18	4,26	5,98	
10	1,44	2,32	4,14	6,02	15,91
12	1,59	2,43	4,49	6,15	15,91
14	1,73	2,77	4,92	6,79	17,61
16	1,73	2,77	4,92	6,79	17,61
20	1,96	3,06	5,42	7,34	17,61
25	2,32	3,43	6,20	8,23	21,02
30	2,58	3,84	6,86	9,08	25,56
35	4,46	5,98	8,06	9,93	33,52
40	5,50	6,42	9,80	11,50	35,79
45	8,12	8,48	12,47	14,00	39,77
50	9,59	9,96	15,15	18,20	43,18
60		15,42	16,66	23,88	54,54
70			26,42	34,07	67,14
80			35,79	43,87	90,90
90				70,00	158,50
100				93,33	176,63

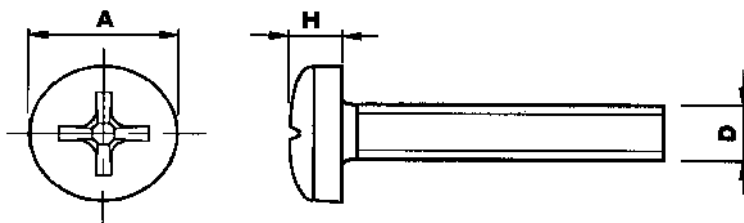
**EURO X 100 PEZZI**  
**CLASSE A2**

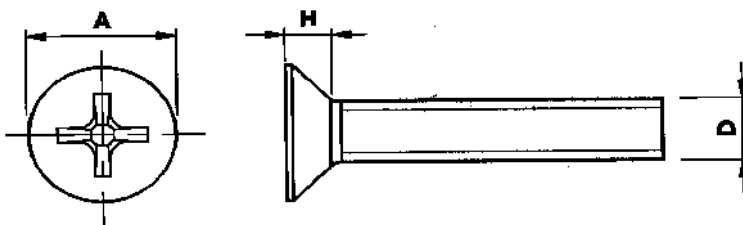

**UNI 7687**  
**DIN 7985**
**VITI METALLO TESTA CILINDRICA TAGLIO CROCE ACCIAIO INOSSIDABILE**

d	3	4	5	6	8
Passo fil.	0,5	0,7	0,8	1	1,25
a	6	8	10	12	16
h max	2,52	3,25	3,95	4,75	6,15
Impronta PH	1	2	2	3	4
4	5,10				<i>EURO X 100 PEZZI</i> <b>CLASSE A4</b>
5	2,90	5,17			
6	2,75	4,82			
8	2,71	4,33	8,07	11,37	
10	2,85	4,67	7,92	11,42	30,30
12	3,15	4,87	8,51	11,69	30,30
14	3,44	5,51	9,35	12,88	33,58
16	3,44	5,51	9,35	12,88	33,58
20	3,89	6,10	10,33	13,95	33,58
25	4,62	6,89	11,81	15,62	40,08
30	5,17	7,67	13,04	17,24	48,73
35	8,95	11,95	15,35	18,91	63,88
40	11,02	12,84	18,69	21,93	68,21
45	16,23	16,97	23,76	26,67	75,76
50	19,19	19,92	28,88	34,70	82,25
60		30,84	31,73	45,53	103,89
70			50,67	64,92	127,90
80			68,18	83,56	173,16
90			35,79	70,00	158,55
100				93,33	176,63

**UNI 7688**  
**DIN 965**
**VITI METALLO TESTA SVASATA TAGLIO CROCE ACCIAIO INOSSIDABILE**

d	3	4	5	6	8
Passo fil.	0,5	0,7	0,8	1	1,25
a max	5,6	7,5	9,2	11,0	14,5
h max	1,7	2,2	2,5	3,0	4,0
Impronta PH	1	2	2	3	4
4	2,69				
5	1,48	2,58			
6	1,40	2,40	5,68		
8	1,36	2,18	4,26	5,98	
10	1,44	2,32	4,14	6,02	15,91
12	1,59	2,43	4,49	6,15	15,91
14	1,73	2,77	4,92	6,79	17,61
16	1,73	2,77	4,92	6,79	17,61
20	1,96	3,06	5,42	7,34	17,61
25	2,32	3,43	6,20	8,23	21,02
30	2,58	3,84	6,86	9,08	25,56
35	4,46	5,98	8,06	9,93	33,52
40	5,50	6,42	9,80	11,50	35,79
45	8,12	8,48	12,47	14,00	39,77
50	9,59	9,96	15,15	18,20	43,18
60		15,42	16,66	23,88	54,54
70			26,42	34,07	67,14
80			35,79	43,87	90,90
90				70,00	158,50
100				93,33	176,63

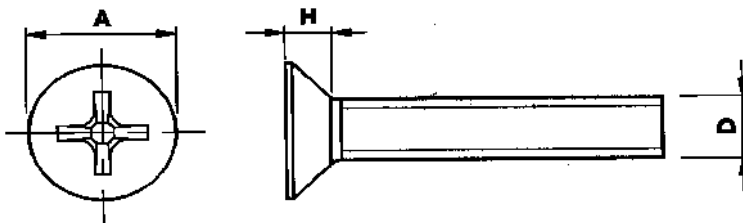
**EURO X 100 PEZZI**  
**CLASSE A2**

**UNI 7688  
DIN 965**
**VITI METALLO TESTA SVASATA TAGLIO CROCE ACCIAIO INOSSIDABILE**

d	3	4	5	6	8
Passo fil.	0,5	0,7	0,8	1	1,25
a max	5,6	7,5	9,2	11,0	14,5
h max	1,7	2,2	2,5	3,0	4,0
Impronta PH	1	2	2	3	4
4	5,10				
5	2,90	5,17			
6	2,75	4,82			
8	2,71	4,33	8,07	11,37	
10	2,85	4,67	7,92	11,42	30,30
12	3,15	4,87	8,51	11,69	30,30
14	3,44	5,51	9,35	12,88	33,58
16	3,44	5,51	9,35	12,88	33,58
20	3,89	6,10	10,33	13,95	33,58
25	4,62	6,89	11,81	15,62	40,08
30	5,17	7,67	13,04	17,24	48,73
35	8,95	11,95	15,35	18,91	63,88
40	11,02	12,84	18,69	21,93	68,21
45	16,23	16,97	23,76	26,67	75,76
50	19,19	19,92	28,88	34,70	82,25
60		30,84	31,73	45,53	103,89
70			50,67	64,92	127,90
80			68,18	83,56	173,16
90			35,79	70,00	158,55
100				93,33	176,63

**EURO X 100 PEZZI  
CLASSE A4**

**UNI 5732  
DIN 603**

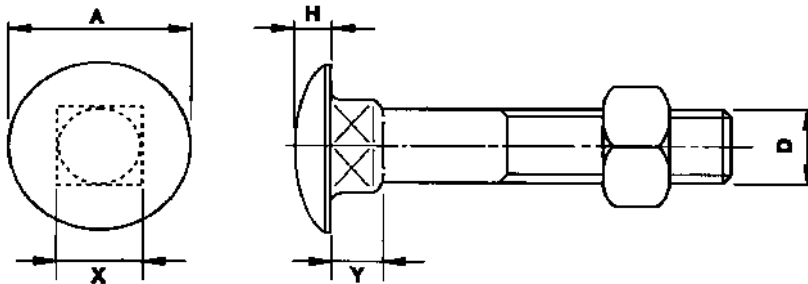

**VITI TESTA TONDA QUADRO SOTTO TESTA ACCIAIO INOSSIDABILE**

d	5	6	8	10	12
Passo fil.	0,8	1	1,25	1,5	1,75
a max	13,55	16,55	20,65	24,65	30,65
h max	2,60	3,88	4,88	5,38	6,95
x max	5,48	6,48	8,58	10,58	12,70
y max	4,10	4,60	5,60	6,60	8,75
16	8,61	13,77	20,66		
20	9,47	14,63	22,38	37,87	
25	10,33	15,49	<b>24,96</b>	41,32	
30	12,05	17,22	27,54	44,76	94,68
35	13,77	18,94	29,27	48,20	99,85
40	15,49	20,66	30,99	51,65	103,29
45	17,22	21,52	32,71	55,09	108,46
50	17,22	22,72	37,87	58,53	113,62
55		24,10	40,46	65,42	118,79
60	25,82	25,13	43,04	68,86	123,95
65	5,17	33,57	48,20	80,05	
70	8,95	37,87	49,92	82,63	129,11
80	11,02	51,65	58,53	94,68	141,16
90	16,23	68,86	72,30	120,51	154,94
100		86,08	86,08	129,11	172,15

**EURO X 100 PEZZI  
CLASSE  
A2**

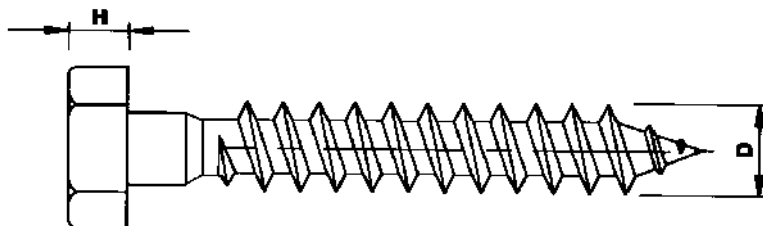
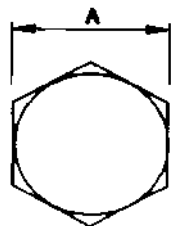

**UNI 704  
DIN 571**

**VITI A LEGNO TESTA ESAGONALE ACCIAIO INOSSIDABILE**

d	5	6	8	10	12
a	8	10	13	17	19
h	3,50	4,00	5,30	6,40	7,50
30	17,75	14,53			
35	19,37	16,14	25,82		
40	20,98	17,75	<b>27,44</b>	54,87	
45	24,21	19,37	29,05	56,49	
50	25,82	20,98	30,66	58,10	96,84
60	29,05	2,40	35,51	64,56	1106,52
70		26,63	40,35	69,40	122,66
80		30,66	46,00	74,24	135,57
90		33,89	51,65	83,29	151,71
100		37,12	58,10	90,38	161,39
110		56,49	88,77	112,97	201,42
120		67,14	96,84	121,04	211,42

**EURO X 100 PEZZI  
CLASSE A2**

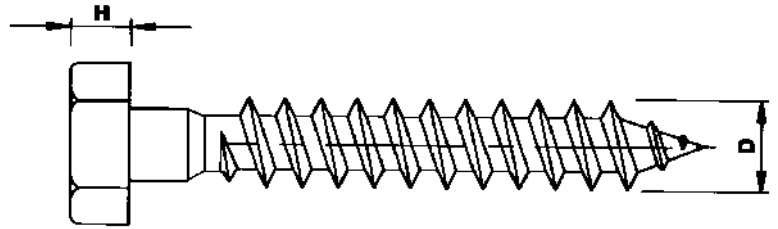
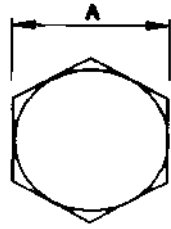

**UNI 704  
DIN 571**

**VITI A LEGNO TESTA ESAGONALE ACCIAIO INOSSIDABILE**

d	5	6	8	10	12
a	8	10	13	17	19
h	3,50	4,00	5,30	6,40	7,50
30	28,41	23,24			
35	30,99	25,82	41,32		
40	33,57	28,41	<b>43,9</b>	87,80	
45	38,73	30,99	46,48	90,38	
50	41,32	33,57	49,06	92,96	154,94
60	46,48	37,44	56,81	103,29	170,43
70		42,61	64,56	111,04	196,25
80		49,06	73,60	118,79	216,91
90		54,23	82,63	134,28	242,73
100		59,39	92,96	144,61	258,23
110		90,38	142,03	180,76	322,27
120		107,42	154,94	193,67	338,28

*EURO X 100 PEZZI  
CLASSE A4*

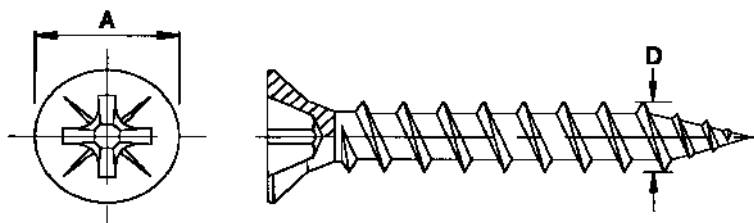

**VITI A PER TRUCIOLARE POZY ACCIAIO INOSSIDABILE**

d	3	3,5	4	4,5	5	6
a max	6,00	7,00	8,00	9,00	10,00	12,00
Impronta PZ	1	1	2	2	2	3
12	1,69	2,10			<b>EURO X 100 PEZZI CLASSE A2</b>	
16	1,86	2,42	2,74			
20	1,94	2,58	2,91	<b>3,23</b>	4,52	7,26
25	2,42	3,07	3,23	3,87	5,16	8,23
30	3,39	3,55	3,55	4,52	5,97	9,20
35		4,20	4,03	5,33	6,46	10,49
40		5,16	4,52	6,29	7,10	11,78
45		49,06	5,65	7,75	8,93	13,56
50			6,62	8,88	6,98	14,53
55					12,59	17,75
60				11,62	11,62	17,43
70					14,53	21,63
80					17,75	25,82
90					20,17	29,05
100					21,95	32,28

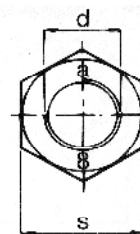
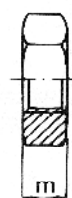
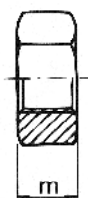
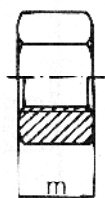

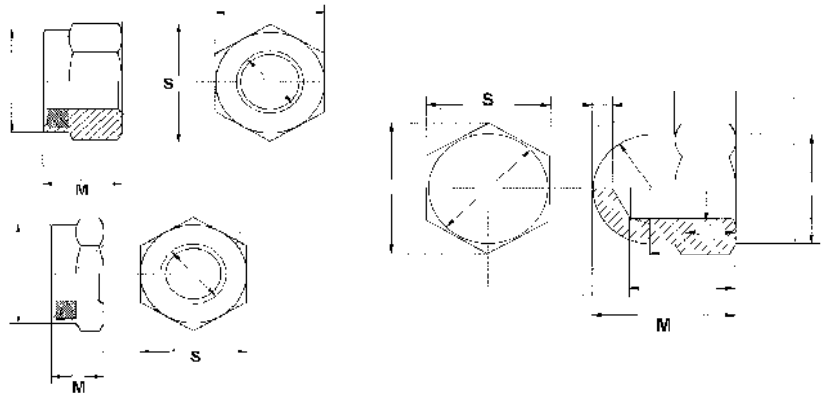

**UNI 5587/8/9  
DIN 934/6**
**DADI ESAGONALI FILETTATURA METRICA ACCIAIO INOSSIDABILE**

FILETTATURA d P. GROSSO	s	m			UNI 5587		UNI 5588 - DIN 934		UNI 5589 - DIN 936	
		5587	5588	5589	A2	A4	A2	A4	A2	A4
<b>EURO X 100 PEZZI</b>										
3X0,5	5,5	3	2,4		1,90	3,40	1,00	1,40		
4X0,7	7	4	3,2		2,10	3,80	1,10	1,50		
5X0,8	8	5	4	3,5	2,30	4,20	1,40	1,80		
6X1	10	6	5	4	3,10	4,80	2,00	2,60	2,40	5,50
8X1,25	13	8	6,5	5	6,00	10,10	4,00	5,30	4,00	8,10
10X1,5	17	10	8	6	13,00	21,60	9,00	11,90	9,60	17,00
12X1,75	19	12	10	7	18,60	29,20	12,70	18,90	12,50	40,00
14X2	22	14	11	8	40,30	67,10	20,70	26,60	27,90	51,60
16X2	24	16	13	8	43,40	72,30	25,60	35,70	29,45	62,00
18X2,5	27	18	15	9	118,80	175,50	43,40	62,00	77,50	134,30
20X2,5	30	20	16	9	98,10	181,00	51,10	67,10	51,10	113,70
22X2,5	32	22	18	10	278,90	372,00	72,30	113,60	185,90	
24X3	36	24	10	10	361,50	501,00	113,60	149,80	113,60	
27X3	41	27	22	12			387,30			
30X3,5	46	30	24	12			449,30			

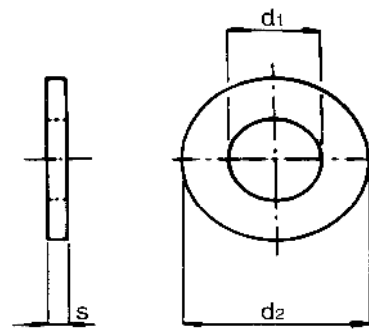

**UNI 7473 - 7474 - 5721**  
**DIN 6924 1887**
**DADI AUTOBLOCCANTI - CIECHI ACCIAIO INOSSIDABILE**

FILETTATURA d P. GROSSO	s	m			UNI 7473 Alto		UNI 7474 Basso		UNI 5721	
		7473	7474	5721	A2	A4	A2	A4	A2	A4
					<i>EURO X 100 PEZZI</i>					
3X0,5	5,5	4	4	6,5	14,80				17,70	
4X0,7	7	6	5	8	3,90	12,00	2,50	3,10	13,20	24,50
5X0,8	8	6,3	5	10	3,70	8,10	2,50	3,30	12,40	21,50
6X1	10	8	6	12	4,60	9,90	2,80	4,23	13,00	22,00
8X1,25	13	9,5	8	15	8,50	14,80	5,60	8,60	24,30	48,00
10X1,5	17	11,5	10	18	17,00	36,90	12,40	17,70	44,20	83,00
12X1,75	19	14	12	22	26,30	56,80	18,60	24,20	72,30	119,00
14X2	22	16	14	25	72,30	149,80	40,30	82,70	191,10	
16X2	24	18	16	28	72,30	154,90	46,50	87,80	232,40	
18X2,5	27	20	17	32	263,40	594,00		402,90		
20X2,5	30	22	17	34	340,90	661,00				
22X2,5	32	25	19	39						
24X3	36	27	21	42						
27X3	41	30	23							
30X3,5	46	32	25							

**(EX UNI 6592)**  
**(EX DIN 125-A)**

**RONDELLE PIANE SERIE NORMALE ACCIAIO INOSSIDABILE**

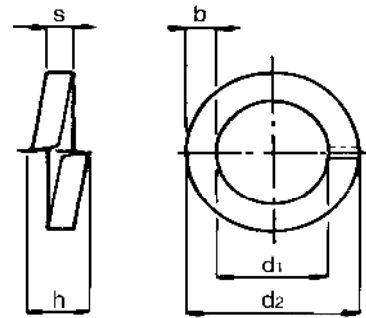
Per viti	d <sub>1</sub>	d <sub>2</sub>	s	CLASSE A2	CLASSE A4
				<i>EURO X 100 PEZZI</i>	<i>EURO X 100 PEZZI</i>
3	3,2	7	0,5	0,51	1,06
4	4,3	9	0,8	0,67	1,44
5	5,3	10	1	0,84	1,95
6	6,4	12,5	1,6	1,53	3,76
8	8,4	17	1,6	2,45	6,90
10	10,5	21	2	4,47	11,17
12	13	24	2,5	7,59	20,97
14	15	28	2,5	12,08	27,76
16	17	30	3	14,38	39,24
18	19	34	3	21,30	49,80
20	21	37	3	22,77	58,85
22	23	39	3	28,49	68,06
24	25	44	4	55,12	114,53
27	28	50	4	72,43	141,85
30	31	56	4	83,88	199,19
33	34	60	5	121,05	290,51
36	37	66	5	153,33	387,34
39	40	72	6	216,27	451,9
42	43	78	7	290,51	

**UNI 1751-B  
DIN 127-B**
**RONDELLE ELASTICHE SPACCATE (GROWER) ACCIAIO INOSSIDABILE**

Per viti	d <sub>1</sub>	d <sub>2</sub>	s	b	h	CLASSE A2	CASSE A4
						<i>EURO X 100 PEZZI</i>	<i>EURO X 100 PEZZI</i>
3	3,1	6,2	0,8	1,3	1,6	0,67	0,90
4	4,1	7,6	0,9	1,5	1,8	0,72	1,07
5	5,1	9,2	1,2	1,8	2,4	0,97	1,49
6	6,1	11,8	1,6	2,5	3,2	1,61	2,34
8	8,2	14,8	2	3	4	2,56	4,15
10	10,2	18,1	2,2	3,5	4,4	3,84	6,34
12	12,2	21,1	2,5	4	5	6,45	10,72
14	14,2	24,1	3	4,5	6	10,31	16,58
16	16,2	27,4	3,5	5	7	14,27	25,80
18	18,2	29,4	3,5	5	7	17,95	28,52
20	20,2	33,6	4	6	8	24,51	42,25
22	22,5	35,6	4	6	8	28,92	45,57
24	24,5	40	5	7	10	46,97	75,60
27	27,5	43	5	7	10	50,14	81,49
30	30,5	48,2	6	8	12	125,71	170,39
33	33	55,2	6	10	12	290,51	
36	36,5	58,2	6	10	12	322,79	

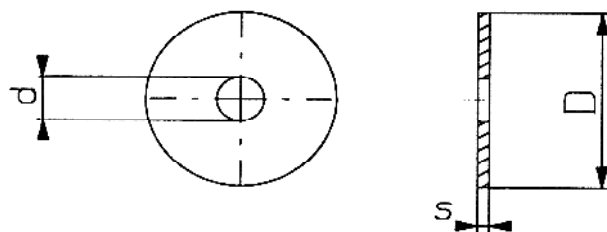
**6593 MT****RONDELLE PIANE LARGHE CON DIAMETRO ESTERNO 3 VOLTE IL FORO  
ACCIAIO INSSIDABILE**

Per Viti				CLASSE A2	CLASSE A4
	d <sub>1</sub>	d <sub>2</sub>	s	<i>EURO X 100 PEZZI</i>	<i>EURO X 100 PEZZI</i>
3	3,2	12	0,8	0,95	0,8
4	4,3	16	1,5	1,47	3,24
5	5,5	20	1,5	2,30	5,43
6	6,6	24	2	3,06	7,84
8	9	32	2,5	7,32	18,86
10	11	40	3	13,05	28,67
12	14	48	4	26,63	55,08
14	16	56	4	43,27	89,03
16	18	64	4	63,91	135,66
18	20	54	4	161,39	274,37
20	22	80	5	209,81	322,79

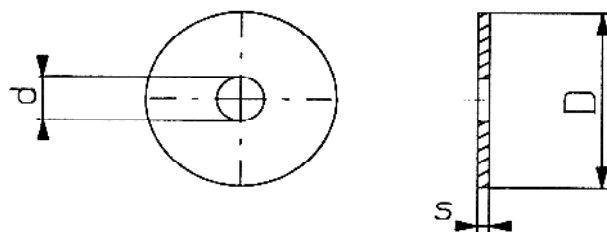

## EXTRA LARGA

RONDELLE PIANE LARGHE CON DIAMETRO ESTERNO 4 VOLTE IL FORO  
ACCIAIO INSSIDABILE

Per Viti				CLASSE A2	CLASSE A4
	d <sub>1</sub>	d <sub>2</sub>	s	EURO X 100 PEZZI	EURO X 100 PEZZI
3	3,2	12	0,8	2,00	7,26
4	4,3	16	1,5	3,36	8,30
5	5,5	20	1,5	5,99	11,17
6	6,6	24	2	10,12	18,86
8	9	32	2,5	17,31	4,71
10	11	40	3	39,94	72,43
12	14	48	4	53,91	104,12
14	16	56	4	112,91	182,59
16	18	64	4	146,46	218,81
20	22	80	5	403,48	